



Montanari Group
GEARLESS & GEARBOX
TRACTION MACHINES



INSTALLATION, USE AND MAINTENANCE
GEARLESS

MGX90 ELEV^o



REV03_02_2024



CHOOSE MONTANARIAPP! Available mobile and desktop.

A unique container of all documentation available for gearboxes, gearless, speed governors and safety gears.

You may check your supply, configure the inverter, download manuals, tech reports, certificates and much more.

Search for Montanari Giulio mobile App, available on Google Play and App store.

**SCAN THE QR TO DOWNLOAD
ANDROID APP**



**SCAN THE QR TO DOWNLOAD
iOS APP**

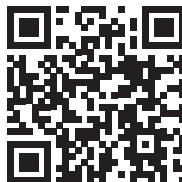

**SCAN THE QR FOR THE DESKTOP
APP**

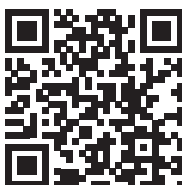

Thank you for choosing a Montanari product.

Since 1970, Montanari Group has been focused on providing its customers with the best traction machines and components for lifts and escalators.

We are proud to have you as a customer and user of the Montanari traction machines, and we are confident that we can work together for a long time.







Thanks again for your choice.

Massimo Montanari
CEO of Montanari Group



REV.	DATE	DESCRIPTION	EDITED BY	VERIFIED BY	APPROVED BY
1	03/02/2023	First Redaction	Marketing Dept	Technical Dept Alberto Mantovani	STEFANO BERTONI (DTE)
2	28/04/2023	Update	Marketing Dept	Technical Dept Alberto Mantovani	STEFANO BERTONI (DTE)
3	09/02/2024	Update	Marketing Dept	Technical Dept Alberto Mantovani	FABIO FORNI (DTE)

WARNING SYMBOLS USED IN THE MANUAL:

	It indicates that safety measures must be taken to avoid electric shock.
	It indicates that safety measures must be taken to prevent personal injury.
	It indicates that safety measures must be taken to prevent damage to components.
	It indicates that safety measures must be taken to prevent burns due to contact with hot/ overheated surface.
	It indicates useful information before and during the installation step.
	It refers to specific parts of the manual.
	It refers to the proper product disposal.

CONTENTS

1.	GENERAL INFORMATION	7
1.1	Introduction.....	7
1.2	Copyright	7
2.	SAFETY.....	8
2.1	Intended use	8
2.2	User's obligations	8
2.3	Correct disposal	9
2.4	Specific hazards.....	9
2.5	Legal References	9
3.	IDENTIFICATION AND DATA	9
3.1	Identification plate	9
3.2	Dimensions.....	11
4.	TRANSPORT AND STORAGE	12
4.1	Handling.....	12
4.2	Storage.....	13
5.	DESCRIPTION	14
5.1	General description.....	14
5.2	Main components	14
5.3	Brake	16
6.	INSTALLATION.....	16
6.1	General installation information	16
6.2	Installation surface.....	17
6.3	Installation procedure.....	17
6.4	Electrical installation - Connections	18
7.	CONNECTION OF THE BRAKE FOR RESCUE SYSTEM.....	21
7.1	Connection of the cable to the release lever	21
7.2	CONNECTION OF THE CABLE TO THE BRAKE LEVERS (MACHINE ROOMLESS).....	22
7.3	Connection of the hand release lever for machine room use and rescue system performance	23
7.4	Procedure:	24



8.	OPERATION	25
8.1	Connections	25
8.2	Additional components.....	25
8.3	General operation information.....	25
8.4	25
9.	TROUBLESHOOTING, MAINTENANCE AND REPAIR	25
9.1	General information	25
9.2	Traction/return sheave.....	26
9.3	Replacement of components	26
9.4	Problems, causes and solutions	26
9.5	Maintenance and repair	27
9.5.1	General indications	27
9.5.2	Description of maintenance activities.....	27
10.	SPARE PARTS	28
10.1	General information	28
10.2	How to order spare parts	28

1. GENERAL INFORMATION

1.1 Introduction

These operating instructions must always be available for consultation. No liability is accepted for any malfunction due to installation not conforming to specifications, except in cases approved by Montanari Giulio & C.

All persons involved in the installation, operation, maintenance and repair of the unit must have read and understood the instructions.

No liability is accepted for damage, breakage or accident caused by failure to follow the instructions.

To make technical improvements, Montanari reserves the right, if deemed necessary, to modify the units and accessories, preserving their essential characteristics and improving efficiency and safety, without notice.

1.2 Copyright

All rights to these operating instructions belong to Montanari Giulio & C. S.r.l. The information in this manual may not be reproduced or used in an unauthorized manner or made available to third parties without prior approval.

If you have any questions, please contact:

MONTANARI GROUP
HEADQUARTER - MONTANARI GIULIO & C. Srl
Via Bulgaria 39 - 41122 - Modena - Italia
Tel: +39 059 453611 - Fax: +39 059 315890
www.montanarigiulio.com
info@montanarigiulio.com



2. SAFETY

2.1 Intended use

The MGX90 gearless machine is supplied ready for safe and reliable use. Any modification by the user that may affect safety or reliability is prohibited; it is also prohibited to tamper with devices or functions designed to prevent accidental contact.



The Montanari MGX90 gearless machine must be used and operated in strict compliance with the conditions set out in the supply contract.

Technical specifications considered: speed, cab capacity, cab weight, presence or absence of compensation, roping at the time of order.

No liability is accepted for any malfunction due to installation not conforming to specifications, except in cases approved by Montanari Giulio & C.

2.2 User's obligations

The operator must ensure that all persons involved in installation, operation, maintenance and repair have read and understood the supplied operating instructions and have adapted to them in order to:

- Avoid damage to property or persons.
- Ensure safe and reliable operation of the unit.
- Avoid breakage and environmental damage due to misuse.

In particular:

- Always observe the relevant environmental and safety regulations when transporting, assembling, installing, operating, maintaining and dismantling the unit.
 - The unit must only be used, maintained and repaired by authorized, properly trained and qualified personnel.
 - The gearless must not be cleaned using high-pressure cleaning equipment.
 - All work must be carried out with care and with due attention to safety.
 - Any work on the unit should only be carried out when it is not in operation.
 - A warning must be placed on the main switch to clearly indicate that work is in progress on the unit.
 - No welding must be carried out on the unit.
 - Do not use the unit as a grounding point for welding operations.
 - If any changes are detected (e.g. overheating or unusual noise) during operation, switch off immediately.
 - Rotating components must be equipped with appropriate guards to prevent contact.
 - If the unit is intended for installation in plant or machinery, the manufacturer of such plant or machinery must ensure that the standards, indications and descriptions contained in these operating instructions are incorporated into its own instructions.

- The information on the warning or identification plates must be complied with. These plates must be kept clean and legible at all times. Missing plates must be replaced.
- All spare parts can be obtained from Montanari Group.

2.3 Correct disposal



Respect the environment and dispose of the product according to the regulations in force in the country of installation.

2.4 Specific hazards

Depending on the conditions of use, the surface of the unit can become very hot.



Danger of burning!

2.5 Legal References

Tab. 1

N	Norm	Description
1	UNI 10147	Maintenance: Terminology.
2	EN 81-20	Safety rules for the construction and installation of lifts - Lifts for the transport of persons and goods.
3	EN 81-50	Safety rules for the construction and installation of lifts - Examinations and tests.
4	EN 81-21	Safety rules for the construction and installation of lifts - Lifts for the transport of persons and goods - Part 21: New passenger and goods passenger lifts in existing building.

3. IDENTIFICATION AND DATA

3.1 Identification plate

The data on the plate are:

Fig. 1 - Example of Identification Plate

The identification plate contains the following information:

- Manufacturer:** Montanari Giulio & C
- Manufacturer's address:** Via Bulgaria, 39, 41122 Modena - ITALY
- QR code to access the relevant documentation.**
- Download App** (with QR code)
- Speed:** 96 - 53 RPM
- Rated torque:** 670 Nm
- Serial number:** 022611
- Frequency:** 25,6 - 14,1 Hz
- Rated current:** 15 A
- Cycle type:** S5 180S/H 40% ED
- Weight:** 330 Kg
- Power rating:** 6,7 - 3,7 kW
- Motor pole no.:** 32 Poles
- Rated voltage:** 380 - 208 V_L
- Year of production:** ANNO YEAR
- Model:** TIPO TYPE MGX90
- Gearless machine code:** CODICE GEARLESS GEARLESS CODE MGX900809638E00
- CE mark**
- MADE IN ITALY**

GEARLESS MACHINE TECHNICAL CHARACTERISTICS: MGX90



Tab. 2

MGX90	Type	Pn	Speed	Vn	Cn	In	Cmax	Imax	EMF	Poles	F	Rs	Ls	Static Load	I	Duty Cycle	Weight
Code machine		kW	[RPM]	[V]	[Nm]	[A]	[Nm]	[A]	[V·s/ rad]	[N°]	[Hz]	[Ω]	[mH]	[Kg]	[kg·m ²]		[Kg]
MGX900812039H0A	MGX90	4,15	48	208	825	23,5	1300	38	20	32	12,8	0,85	15	3000	2,8	240S/H 40%	340
MGX900817039H0A	MGX90	7,35	85	208	825	33	1300	53	14	32	22,7	0,43	8	3000	2,8	240S/H 40%	340
MGX900810429H0A	MGX90	9	104	208	825	38	1300	65	12	32	27,7	0,32	5,9	3000	2,8	240S/H 40%	340
MGX900816029H0A	MGX90	13,8	160	208	825	56	1300	94	8,5	32	42,7	0,15	2,8	3000	2,8	240S/H 40%	340
MGX900804839H0A	MGX90	4,15	48	380	825	13	1300	20	37	32	12,8	2,9	53	3000	2,8	240S/H 40%	340
MGX900808539H0A	MGX90	7,35	85	380	825	18,5	1300	30	25	32	22,7	1,4	25	3000	2,8	240S/H 40%	340
MGX900812039H0A	MGX90	10,4	120	380	825	23,5	1300	38	20	32	32	0,85	15	3000	2,8	240S/H 40%	340
MGX900817039H0A	MGX90	14,7	170	380	825	33	1300	53	14	32	45,3	0,43	8	3000	2,8	240S/H 40%	340
MGX900810429H0A	MGX90	17,3	200	380	825	38	1300	65	12	32	53,3	0,32	5,9	3000	2,8	240S/H 40%	340

Tab. 3

BRAKE CHARACTERISTICS			
Model	Brake model	Power	Braking Force
		[W]	[Nm]
MGX90	EMF02	2x130	2x850
		[V]	[A]
		104V _{DC}	2x1.2
			Certificate
			EDPS 027

3.2 Dimensions

The technical drawing and the overall dimensions follow.

Tab. 4

MGX90				
Pulley		Ropes		
ØD	F	Ø	max	Pitch
mm	mm	mm	n°	mm
400	92	10	5	17
480			6	14
520		12	5	17
		13	4	20

Fig. 2
MGX90

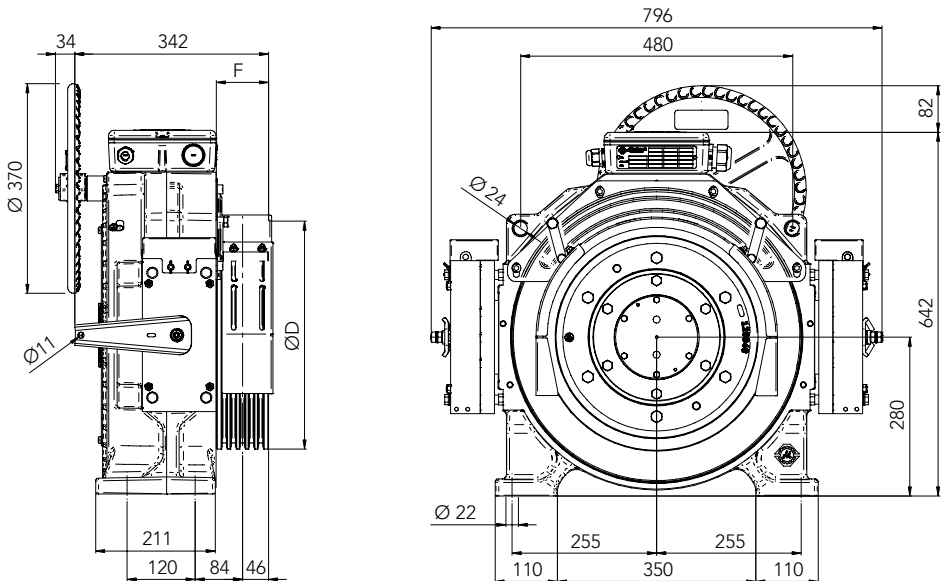



Only use lifting systems and equipment with adequate lifting capacity for handling. The entire packaging is designed to allow movement with for lift and for lift truck.

4. TRANSPORT AND STORAGE

4.1 Handling

All gearless machines are packed in crates or cages.

Different types of packaging can be used, depending on the size and means of transport. Unless otherwise specified, the packaging complies with the HPE guidelines.

In some cases, the machines are mounted on wooden pallets to enable them to be transported correctly on trucks. The packaging may not be stacked in any way. It is recommended to check the conditions of the material when it is received. In case of damage, do not proceed with the installation unless expressly authorized by Montanari Giulio & C. Observe the symbols on the packaging to prevent damage to property or personal injury. Here are the meanings of the symbols that may appear on the packaging.



Keep dry



Handle with care



Attachment point



Upper side



Do not use hooks



Keep away from heat sources



Fragile



Center of gravity



For lifting, anchor points (eyebolts) are provided as shown in Fig. 3.

Use only the specified eyebolts to handle the unit.

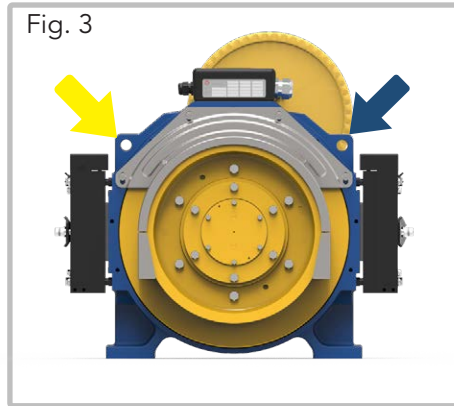

4.2 Storage

The gearless machine must be stored in the position of use on a wooden base not subject to vibrations, in a covered and sheltered place.



If the unit is stored outdoors, it should be covered, taking care that no moisture and/or other foreign matter can accumulate on it.



Supplies for special environmental conditions during transport (e.g. by ship) and storage (climate, temperature, etc.) must be contractually agreed.



- Check the correct operation of the motor and brake after installation.
- Repairs may only be carried out by the manufacturer or by authorised personnel.
- The machine can be red-hot.
- These machines must be connected to inverters.
- When the machine is rotating, both manually and mechanically, it can act as a generator and produce high voltage.
- During configuration, the machine is powered by high voltage.



5. DESCRIPTION

5.1 General description

The MGX90 series gearless machines are permanent magnet motors with double brake system.

5.2 Main components

The unit consists of the main groups as shown in Fig. 4 - 5

MGX90 is equipped with a PTC thermal probe inside the windings to protect against overheating (winding temperature up to 130°C) and with a thermo-contact for the activation of the fans. Refer to the electrical connections for more details. -  See Par. 6.4.

Lubrication



The gearless machine contains no oil and it is supplied with bearings already lubricated throughout the life of the machine; no further lubrication is required.

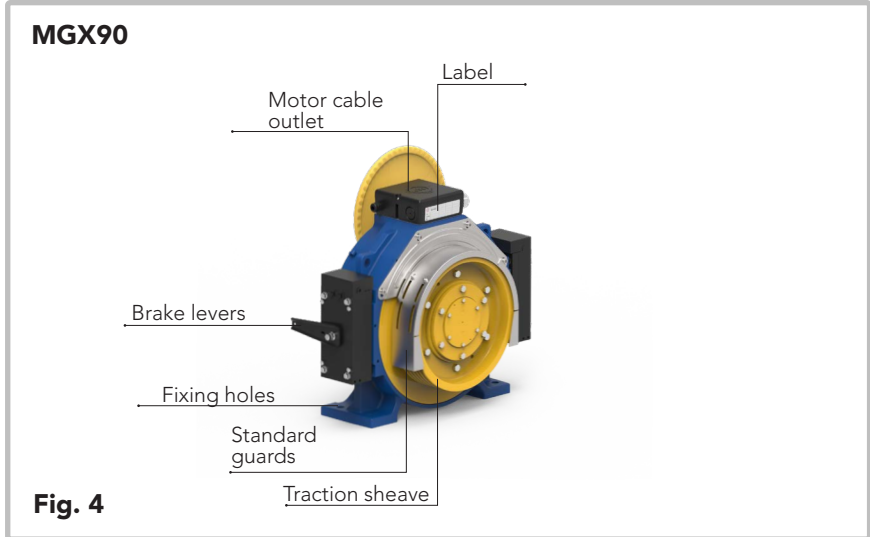

MGX90

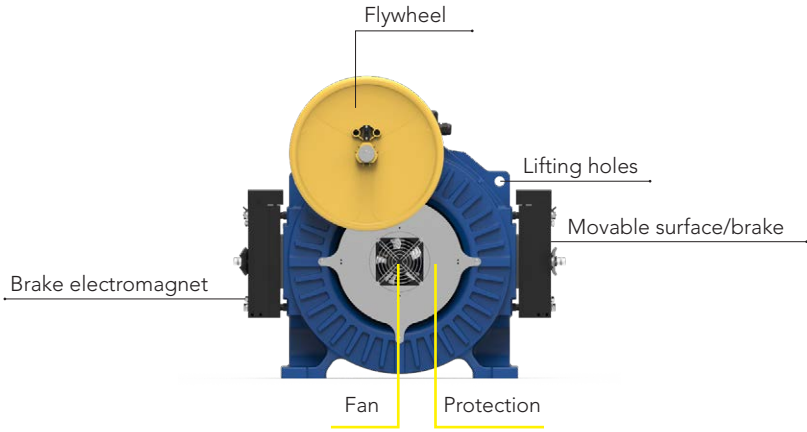

Fig. 5



5.3 Brake

The gearless machine is supplied with a brake that conforms to the standards indicated in paragraph 2.5.

The brake system is pre-calibrated by the manufacturer and no further adjustment is required.



The brake system operates as follows:

- **Not powered** (electromagnet not powered): the brake disc is clamped by the movable surfaces (yellow arrows on Fig. 6). In this condition the system does not move.
- When the brake electromagnet is **powered**, it releases the brake disc (yellow arrows in Fig. 7); now the motor is released.

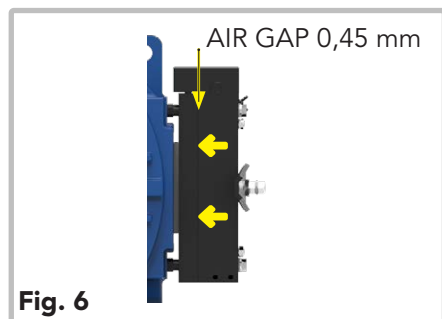

Fig. 6
Brake system not powered

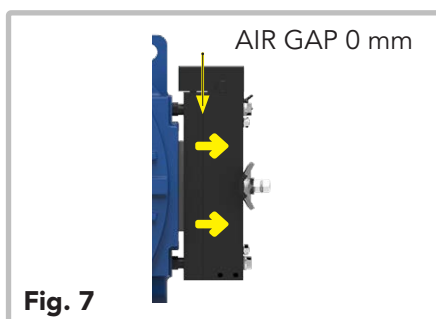

Fig. 7
Brake system powered

6. INSTALLATION

6.1 General installation information



The gearless machine must be installed in a building or in a closed travel compartment.

Do not use the gearless machine in an explosive atmosphere.

The room temperature must be between 0°C and +40°C.

Assembly and installation must be carried out with great care by qualified and trained personnel.

The manufacturer cannot be held responsible for damage caused by incorrect assembly or incorrect installation.

Before starting work, make sure that adequate lifting and handling equipment is available.

No welding work must be carried out on the unit.

The unit must not be used as a grounding point for welding operations. The bearings can be irreparably damaged.

All fixing points specified by the manufacturer must be used.

The air supply for cooling must not be prevented.

6.2 Installation surface

The installation surface must be uniform and level.

The levelling tolerance is 0.2 mm.

The installation surface must be rigid and robust enough to withstand the forces involved.

6.3 Installation procedure

The gearless machine can be lifted using the eyebolts for the insertion of the belts or lifting chains (see also the paragraph on storage and handling). Particular attention is needed to avoid that the gearless machine receives blows in correspondence of the brake disc; the brake levers and the electrical connections of the board are very delicate. Lifting example Fig. 8.

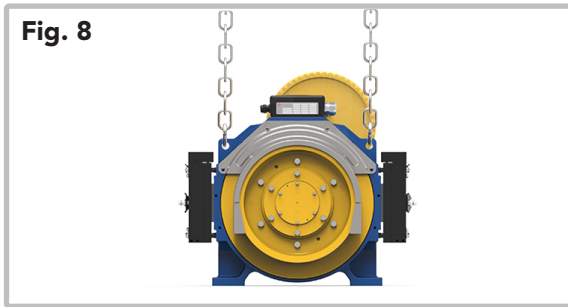

Place the unit on the installation surface and secure it.

- Fixing screws and nuts must be tightened to the prescribed torque.
- Use bolts with a minimum strength class of 8.8.
- Do not force or hit the fixings to position them; this could damage the bearings, rings, etc.
- Mount the safety devices.



The static load changes depending on the roping direction. (Fig. 9):

Load direction

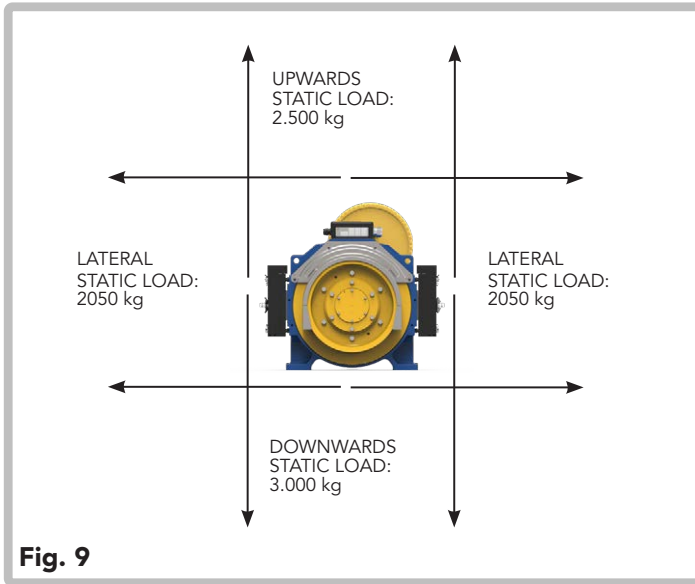

6.4 Electrical installation - Connections

The Gearless is provided of terminal block:

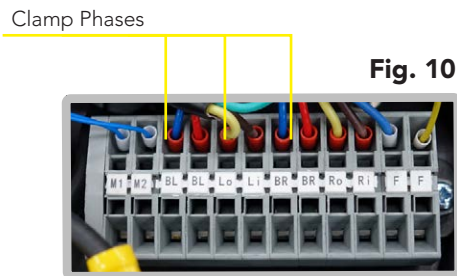

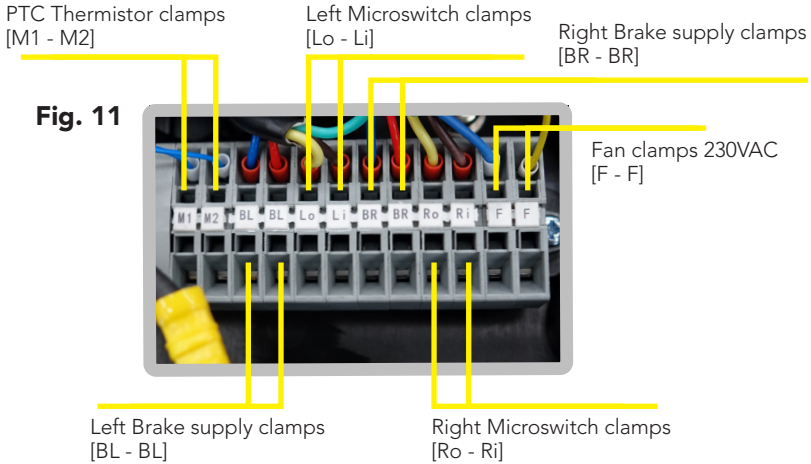

- The power cable must be routed separately from the other cables.
- The motor power cable is shielded and the shield must be grounded.
- The encoder cable must be routed away from the motor power cable to avoid electrical interference.
- The brake system has a power cable and another cable for the microswitch contacts. All electrical data are listed on the label of the brake system. The microswitch has two contacts: one open and one closed. (Fig. 12). These contacts indicate the brake condition (tab. 5).

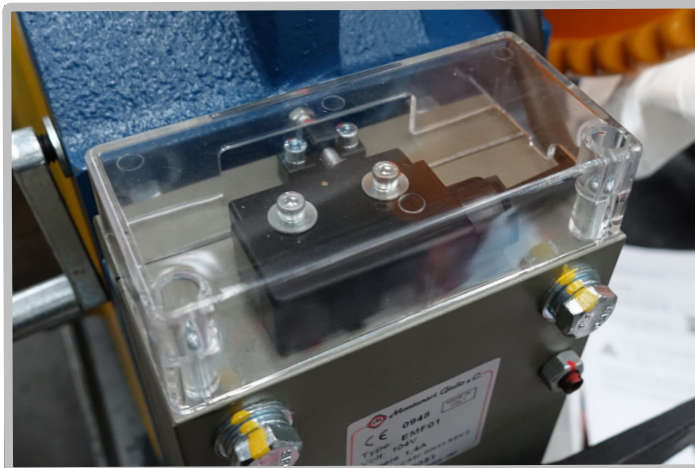



Fig. 12



Tab. 5

Brake disc closed	Condition contact	Brake disc free	Condition contact
COM.  N.O.	Disconnected	COM.  N.O.	Connected

Below an example for setting the parallel connection of the brake coil.

- **Standard mode:**

It is possible controlling only contactor 1 and leaving contactors 2 and 3 closed. (Fig. 13).

This protects the brake from dangerous overvoltage and noise when closing.

- **Emergency mode and inspection mode:**

The use of all contactors is recommended. Using only contactor no. 1 during opening and/or closing operations may cause an unacceptable delay when closing the brake.

Fig. 13 Typical application with brake coils in parallel configuration.

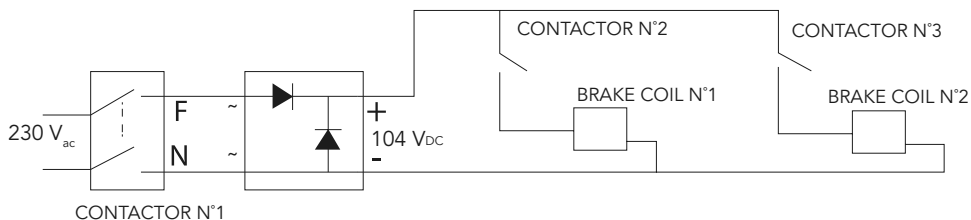

7. CONNECTION OF THE BRAKE FOR RESCUE SYSTEM

The cable and release lever can be supplied on request.
The kit is shown in Fig. 14.

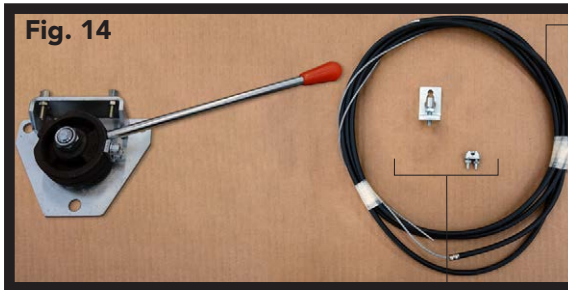

Connection cable for brake levers for manual rescue system (3.5 m).

Components for fixing the cable.

7.1 Connection of the cable to the release lever

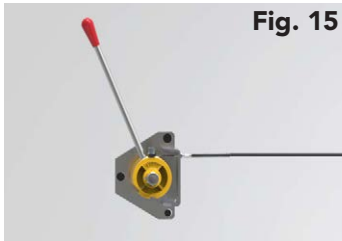

Fig. 15

Fix the lever to the wall with the bolts (not supplied). Connect the cable to the support as shown in Fig. 16.

Insert the other end of the cable into the screw hole. Tighten to stop. Fig. 16.

Fig. 16





7.2 Connection of the cable to the brake levers (**machine roomless**)

Insert the end of the cable into the lever holes. Tension and fix. Fold the end and secure with the rope clamp as shown in the figure. At the end, the result is as in the figures below. By connecting together the phases, (short circuit) the cab will move slowly.

Fig. 17

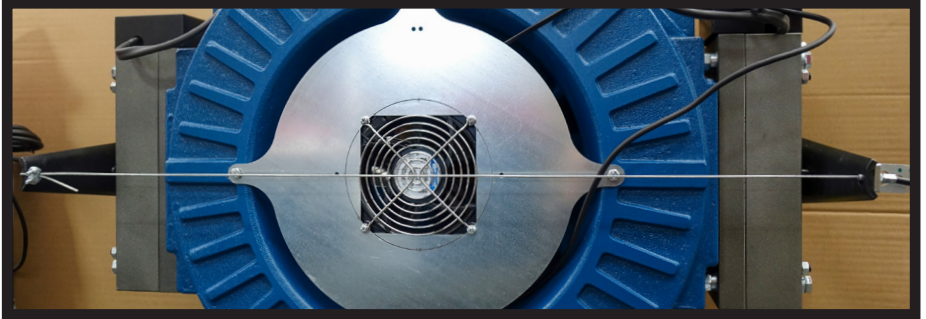

Fig.18 - 19 Details about the correct connection of the cable to the levers.



Fig. 18



Fig. 19

7.3 Connection of the hand release lever for machine room use and rescue system performance

IMPORTANT: When the flywheel is hung, the contact remains closed and allows normal operation of the elevator. When the flywheel is removed, the contact opens and inhibits the operation of the elevator (to prevent risk to persons). It is the responsibility of the customer/plant maintainer to connect the contact in the switchboard so that everything works properly.

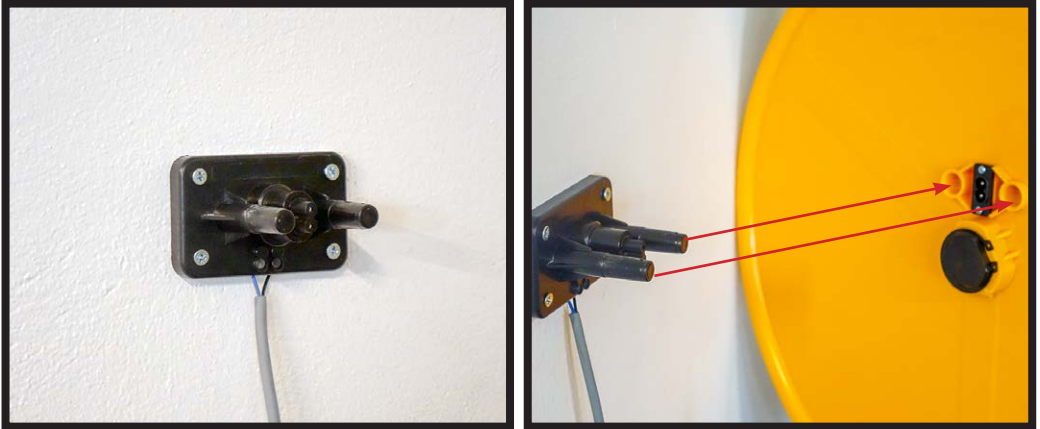

To slow down the car, it's recommended to connect the phases together (short circuited connection).

Connection and installation must be carried out in such a way that the lever and the flywheel can be operated simultaneously. Fig. 22.

This allows you to perform the rescue system operation correctly.



1. Place the flywheel into the appropriate hole as shown in the figures 20 - 21.
2. Place the two extremities of the mechanism levers release in the holes of the brake as shown in the figure below.

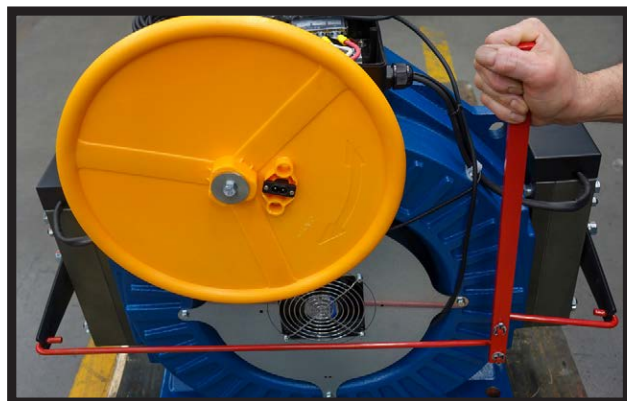
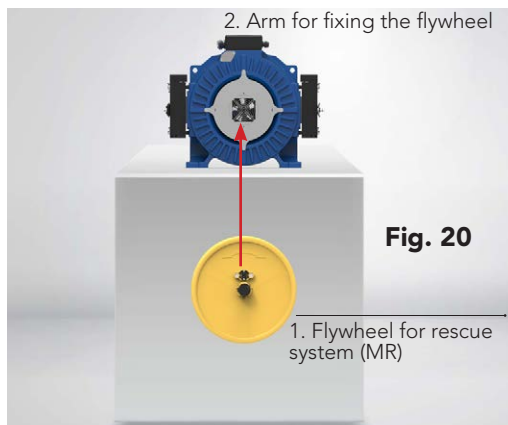

4. Lever for rescue system connected to the brake levers by cable (all included in the supply).

Fig. 22

7.4 Procedure:

- Stop the system
- Calm any people inside the cab.

Grasp the flywheel firmly (Fig. 22).

Operate lever (Fig. 22) for manual brake release. Red arrow direction. Slowly turn the flywheel in the right direction to move the cab until the floor is reached.

Close the brake by releasing the lever: green arrow direction.

Open the floor door and the cab door to free the people inside.

Note: the company carrying out the maintenance of the lift system is responsible for these operations.

8. OPERATION

8.1 Connections

Connect the motor, brake, and monitoring devices.

The connection must be made by qualified personnel in accordance with the applicable safety regulations. Installation and operation requirements and current national and international standards must be met.

8.2 Additional components

If third party additional components or options are installed, please refer to the information in the respective separate documentation provided.

8.3 General operation information

When operating the MGX90 unit, be sure to check that the following situations do not occur:

- Excessive operating temperature.
- Excessive and unusual noise.

If any irregularity occurs during operation, turn off the power immediately. Identify the cause of the malfunction by using the table in Chap. 9, containing a list of possible problems, causes and suggested remedies.

8.4

The safety gear can be released via the gearless machine without exceeding the I_{max} current limit shown in Tables 2 and 3. If this is not possible, it must be released with other means. However, it is always advisable to act on the weight in the cab in order to facilitate the releasing operation.



If the cause of the malfunction cannot be identified, or if the unit has been repaired using the means available, you should contact one of our service centres for a specialised service.

9. TROUBLESHOOTING, MAINTENANCE AND REPAIR

9.1 General information



Problems and malfunctions occurring during the warranty period, which are not precisely identified or which require work on the unit, must be referred to the manufacturer's Customer Service department.

Observe all safety rules.

Do not disassemble the motor on site.

The bearings are protected and do not require any additional lubrication under standard conditions of use.

Do not use high-pressure cleaners on the motor.

Montanari cannot guarantee or be held responsible for unauthorized operations on the unit, improper use, modifications made without its consent or the use of non-genuine spare parts.



When repairing problems or malfunctions, the unit must be put out of service in order to prevent unintentional start-up. Place a warning sign on the starting switch.



9.2 Traction/return sheave

Periodically, at least once a year, check the wear of the grooves in the traction sheave.

In case of slipping ropes or excessive wear, contact Montanari Giulio & C. for replacement instructions, always indicating the serial number.

9.3 Replacement of components

Instructions for the replacement of any component must be requested each time from the technical department specifying the serial number.

9.4 Problems, causes and solutions

Tab. 6

Diagnostic Table		
Problems	Causes	Solutions
The motor does not work	Motor phases are connected in the wrong way	Check the connection condition of the motor phases
	Wrong inverter configuration	Check the inverter settings
	Inverter defective	Replace the device
	Brake faulty	See below
	Motor mechanically locked	Contact Montanari Giulio & C.
	Motor connections loosened	Tighten the connections of the machine controller.
	Excessive temperature	See below
Brake system not working	Brake power supply wrong	Check the correct supply voltage of the brake coil.
	Brake system defective	Contact Montanari Giulio & C.
Excessive temperature	Cooling fan not working.	Replace the fan
	Cooling fan not correctly connected.	Check the voltage of the cooling fan. (230 V ac)
	PTC sensor defective	Contact Montanari Giulio & C.
	Wrong inverter settings	Check the inverter settings
Noise while travelling	Alignment of the motor with the deflection sheave incorrect.	Check and correct the alignment.
	Encoder defective	Replace encoder
	Wrong inverter settings	Check the inverter settings
	Bearing defective	Contact Montanari Giulio & C.

9.5 Maintenance and repair

9.5.1 General indications



The unit must only be used, maintained and repaired by authorized, properly trained and qualified personnel.

Compliance with the inspection and maintenance intervals is part of the conditions for the validity of the warranty.

9.5.2 Description of maintenance activities

Stop the unit and put it out of service. Place a warning sign on the start switch to prevent unintentional start.

Cleaning the unit.

Remove dirt on the unit with a hard brush.

Remove corrosion signs.

The unit must not be cleaned with high pressure washing equipment.



10. SPARE PARTS

10.1 General information



TIP

By keeping the main spare parts and wear parts in stock, the unit can always be used.

10.2 How to order spare parts

The manufacturer guarantees only genuine spare parts and accessories supplied by him.

Other parts not supplied by the manufacturer have not been tested or approved. The use of these parts can therefore compromise certain characteristics of the gearless machine and expose it to active and passive safety risks.



The manufacturer will not assume any responsibility and will not recognize warranty for damage caused by spare parts and accessories not supplied by the manufacturer himself.

When ordering spare parts, always specify:

- Order no. of the machine to which they must be applied;
- Part code;
- Description;
- Quantity.

To order spare parts, write to **service@montanarigiulio.com**.



Montanari Group
GEARLESS&GEARBOX
TRACTION MACHINES

MONTANARI GROUP HEADQUARTER
Montanari Giulio & C. Srl

Via Bulgaria 39 - 41122 - Modena - Italia

Tel: +39 059 453611 - Fax: +39 059 315890 - info@montanarigiulio.com

www.montanarigiulio.com

