



Italia

CERTIFICATE

Lift Directive 2014/33/EU - CE type-examination certificate for safety components (ref. Annex IV – A)

Certificate No.:	EDPS 027
Holder:	Montanari Giulio & C. S.r.l. Via Bulgaria 39/A I-41122 Modena (MO)
Date of submission:	04/05/2022
Manufacturer:	Montanari Giulio & C. S.r.l. Via Bulgaria 39/A I-41122 Modena (MO)
Product:	Device against overspeed for the car moving in upwards direction and as stopping for protection against the uncontrolled movement of the car - subsystem.
Model/type:	EMF02
Reference standards:	EN 81-20: 2020 EN 81-50: 2020
Test report:	ALU20220623-01-722292974

It is certified that the safety components in the field of application indicated in the attachment to this certificate, satisfy the essential safety requirements of Directive:

2014/33/EU

First issue date: 6th July 2022
Issue date: 6th July 2022



PRD N° 081B

Membro degli Accordi di Mutuo Riconoscimento
EA, IAF e ILAC
Signatory of EA, IAF and ILAC Mutual
Recognition Agreements



Alberto Carelli
Industry Service Director
TUV Italia S.r.l.

Notified Body Identification Number: 0948

This certificate is valid only if accompanied by the pertinent annex

PAS 02_M003__rev. 06 del 16/06/2022

	Attachment to EU-type examination certificate n° EDPS 027	Issue date:	6 th July 2022
		Pg. 1 of 4	

1 Field of application

1.1. The field of use of the brake is summarised in the following table:

Maximum rated torque [Nm]	Maximum rotation speed [rpm ⁻¹]	Maximum brake response time (10% of torque) [ms]	Maximum brake response time (50% of torque) [ms]	Maximum brake response time (90% of torque) [ms]
2x850	280	50	75	110

2 Main technical features

2.1 To provide identifying elements and information regarding construction and operation, environmental conditions, connection requirements and compliance with the tested and approved type, the EU-type examination certificate and this annex must be accompanied by the drawing: 5249054300 R00, 17/06/2022

3 Conditions for validity of certificate

- 3.1 Given that the braking device is only part of the safety device protecting against uncontrolled car movements during upward acceleration, an overspeed governor compliant with section 5.6.6 of standard EN 81-20 must be used to control the upward acceleration speed of the car.
- 3.2 The overspeed governor, compliant with section 5.6.6 of standard EN 81-20, must trip the braking device by way of its own electrical contact. Alternatively, devices compliant with section 5.6.6.10 of standard EN 81-20 can be used, specifically devices equivalent to overspeed governors, provided they have EU-type approval.
- 3.3 The mechanical movement of each braking circuit is separately and directly controlled by a micro-switch in order to guarantee the redundancy specified in section 5.6.6.2 of standard EN 81-20. In the event, with the car at a standstill, the braking element does not intervene, all subsequent car movement must be inhibited.
- 3.4 If the traction machine moves with the brake closed, all subsequent operations must be inhibited, and the next lift movement must be prevented.
- 3.5 As indicated in standard EN 81-20 section 5.9.2.2.2.2, the braking device works directly on the traction sheave or on the shaft of the traction sheave, or in its immediate vicinity.
- 3.6 The braking device, if suitably interfaced with a detection system, which in turn has EU-type certification, can act as the sub-system of a device to protect against uncontrolled car movement.
- 3.7 Given that the brake referred to by this certificate is a device used during normal lift operation, the lift installer is responsible for ensuring its continuous test monitoring, to ensure the correct opening and closure of the braking mechanism. Efficient brake opening and closure must be tested by a control circuit based on signals emitted by two micro-switches already installed on the brake by the Manufacturer of the brake itself. As an alternative to testing the efficient opening or closure of the mechanism using micro-switches, the braking force can be routinely tested using a suitably certified device. In the event of a fault, subsequent normal lift start-up must be inhibited.
- 3.8 The monitoring device, connected downstream of the micro-switches installed on the brake, or the device used to perform routine tests on braking force, are not included in this certificate and must have EU-type approval (see 5.6.7.3 of EN 81-20, only partially satisfied by this certificate).

	Attachment to EU-type examination certificate n° EDPS 027	Issue date:	6 th July 2022
		Pg. 2 of 4	

4 Notes

- 4.1 The person responsible for designing the lift, based on the value of the braking torque, the system geometry (moments of inertia and sheave diameters, type of suspension, winch layout) and system masses (load, car mass, counterweight mass, rope mass, flexible cable mass, compensation rope mass, etc.), must check that car deceleration during an upward-moving emergency stop, does not exceed a value of 1 g (see EN 81-20, section 5.7.3.3)
- 4.2 The person responsible for designing the lift, based on the system geometry (moments of inertia and sheave diameters, type of suspension, winch layout) and system masses (load, car mass, counterweight mass, rope mass, flexible cable mass, compensation rope mass, etc.) must check that the torque value required for emergency braking does not exceed the maximum values of the brake application range.
- 4.3 Pursuant to that provided for by the Lifts Directive 2014/33/EU, the applicant must inform the notified body of any modifications, even those of minor importance, already made or which will be made to the safety component to which the certificate refers.
- 4.4 The values in tab. 1 are an average of the measurements obtained on a sample electrically powered brake, compliant with the manufacturer's instructions.
- 4.5 The machine brake must be connected to a suitable switch device able to detect uncontrolled car movement, and a device that monitors correct brake operation.
- 4.6 The switch device used to detect uncontrolled car movement, combined with the car stopping element, must have characteristics and response times compatible with those indicated in this certificate, must comply with the interfacing instructions issued by the brake Manufacturer (edition rev. 9.1) and must be compliant with section 5.6.7 of EN 81-20.
- 4.7 Certification for the uncontrolled car movement detection and interruption device is not included in this document.
- 4.8 During the final lift test, the operation of the device protecting against uncontrolled car movement must be checked pursuant to section 6.3.11 and 6.3.13 of EN 81-20. Correct interfacing between the device used to detect uncontrolled movement and the stopping device, must also be tested.
- 4.9 The device used to monitor correct brake operation must also be tested prior to being placed into operation.
- 4.10 A preliminary condition for the validity of this certificate is that the manufacture of the safety component has been verified as compliant with the requirements specified in the Lifts Directive 2014/33/EU, annex IX, module C2 or Lifts Directive 2014/33/EU, annex VI, module E, product quality guarantee.
- 4.11 Any changes to the design or use of the safety component, which are not included in section 1: "Field of application" must be immediately communicated to the CAB in writing.
- 4.12 The assigned certificate number cannot be used for products different to those which are the object of the test.
- 4.13 Manufacturer of the series production: Wuxi Hengxin Machinery & Electric Manufactory Co. Ltd, A6-5 Liyuan Development Zone, Wuxi, China



Attachment to EU-type examination certificate

n° EDPS 027

Issue date:

6th July 2022

Pg. 3 of 4

Rated Torque: $\geq 850\text{Nm}$

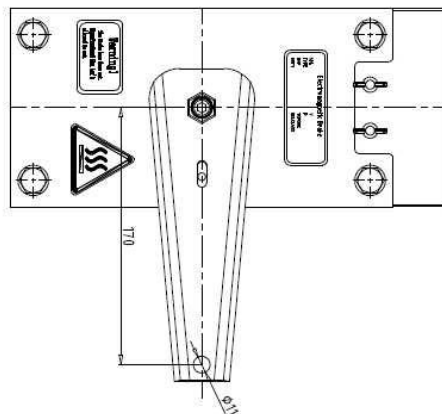
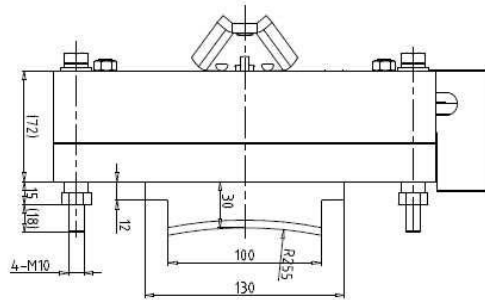
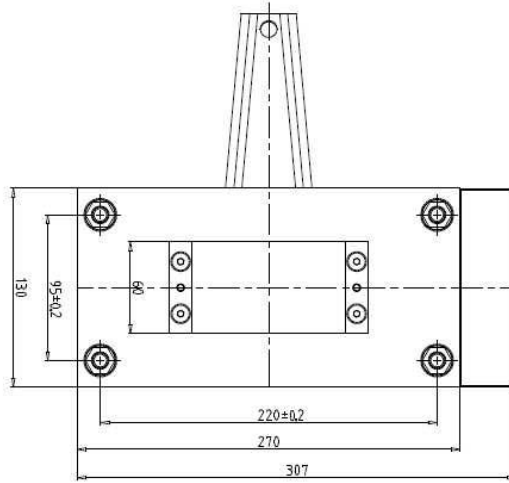

REV.	DATA	DESCRIZIONE REVISIONE	PROGETTISTA	VERIFICATO	APPROVATO	COLLABORATORE
00	17/06/2022	Disegno prodotto in base alla				

5249054-300		R00
--------------------	--	------------

MODELLO 5249054-300 DESCRIZIONE R00	REVISIONE R00
--	-------------------------

AUTORE A2	VERIFICATO (1.1)
---------------------	----------------------------

MODELLO 5249054-300 DESCRIZIONE R00	REVISIONE R00
--	-------------------------

MODELLO 5249054-300 DESCRIZIONE R00	REVISIONE R00
--	-------------------------

MODELLO 5249054-300 DESCRIZIONE R00	REVISIONE R00
--	-------------------------

MODELLO 5249054-300 DESCRIZIONE R00	REVISIONE R00
--	-------------------------

MODELLO 5249054-300 DESCRIZIONE R00	REVISIONE R00
--	-------------------------



**Attachment to EU-type
examination certificate**

n° EDPS 027

Issue date:

6th July 2022

Pg. 4 of 4

