



Montanari Group

GEARLESS & GEARBOX
TRACTION MACHINES



GEARLESS

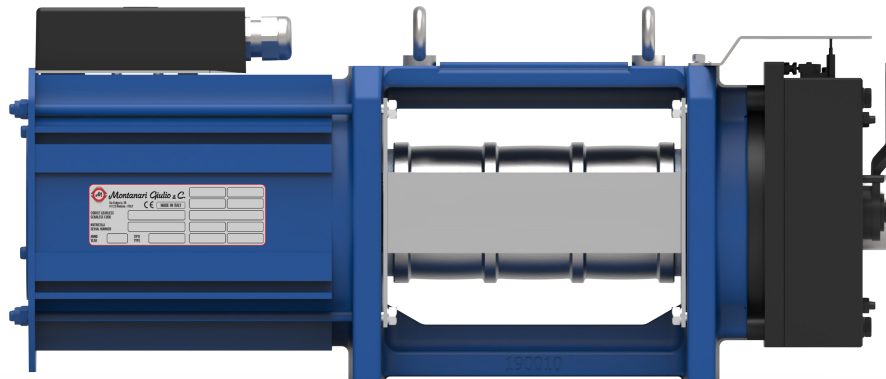

static load
carico statico
 2000 kg

load
portata
 up to 630 kg

speed
velocità
 up to 2 m/s

roping
tiro
 2:1

weight
peso
 120 kg

Encoder	Poli Poles	Momento Torcente Nominal Torque	Codice IP IP Code	CINGHIA - BELT				
				Pulley diam	width	min - max	Passo Pitch	TIPO/TYPE
		Nm			mm	n°	mm	
Endat SinCos SSI BISS	16	104 S5-40%	IP41	100	30	3	65	PIATTO FLAT
				85	33	2	?	
Freno - Brake								
2x125Nm 2x64W 207VDC Mayr								

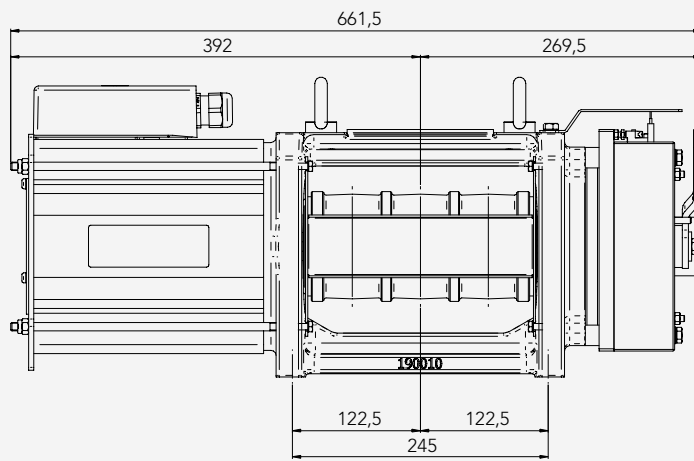
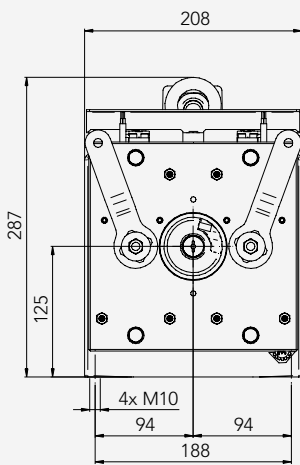
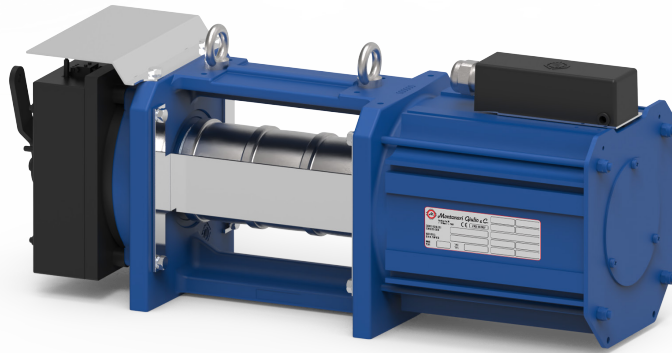
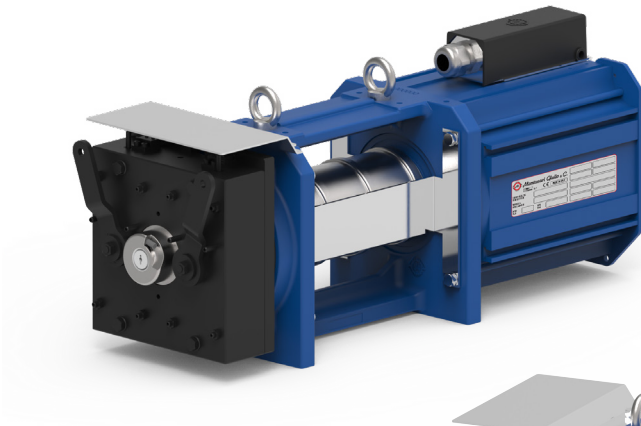

Per Impianti Ascensore a cinghia For Belt Elevators



Load range - Portate
630 - 800 kg

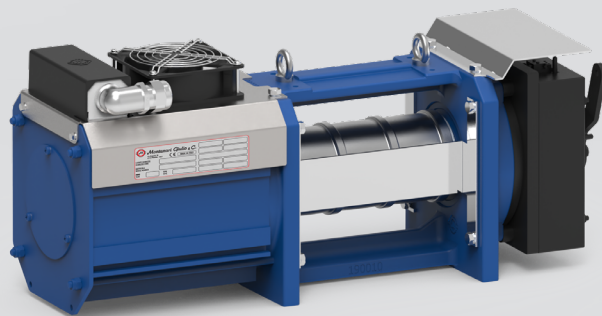
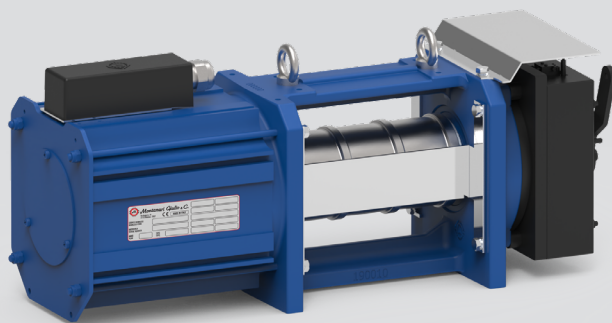

Montanari Group
GEARLESS&GEARBOX
TRACTION MACHINES

MONTANARI GROUP

HEADQUARTER
MONTANARI GIULIO & C. Srl
Via Bulgaria, 39
41122 - Modena - Italy

+39 059 453611
+39 059 315890
www.montanarigiulio.com
marketing@montanarigiulio.com

website



linkedin



facebook

