



# TYPE EXAMINATION CERTIFICATE

According to Lifts Regulations 2016, Schedule 11, Section A

<b>Certificate No.:</b>	UK-BD 1014/1
<b>Approved Body:</b>	TUV SUD BABT UNLIMITED Octagon House Concorde Way, Segensworth North Fareham, Hampshire, PO15 5RL, UK Identification No. 0168
<b>Certificate Holder:</b>	Chr. Mayr GmbH & Co. KG Eichenstr. 1 87665 Mauerstetten - Germany
<b>Manufacturer of the Test Sample:</b> <small>(Manufacturer of Serial Production - see Enclosure)</small>	Chr. Mayr GmbH & Co. KG Eichenstr. 1 87665 Mauerstetten - Germany
<b>Product:</b>	Braking device acting on the shaft of the traction sheave, as part of the protection device against overspeed for the car moving in upwards direction and braking element against unintended car movement
<b>Type:</b>	RTW Size 600, 800, 1000, 2000 Type 8012. _ _ _ . _ _
<b>Regulation:</b>	Lifts Regulations 2016
<b>Reference Standards:</b>	EN 81-20:2020 EN 81-50:2020
<b>Test report:</b>	UK-BD Chr. Mayr dated 2022-05-24
<b>Outcome:</b>	The product conforms to the essential health and safety requirements of the mentioned Regulation if the requirements of the annex to this type examination certificate are kept.
<b>Date of Issue:</b>	2022-05-27

  
Achim Janocha

TUV SUD BABT UNLIMITED



**1 Scope of application**

**1.1 Use as braking device – part of the the protection device against overspeed for the car moving in upwards direction – permissible brake torques and tripping rotary speeds**

1.1.1 Permissible brake torques and maximum tripping rotary speeds of the traction sheave when the brake device acts on the shaft of the traction sheave while the car is moving upward

Size	Permissible brake torque [Nm]	Max. tripping rotary speed of the traction sheave [rpm]
600	800 - 1200	500
800	1100 - 2000	
1000	1600 - 2700	
2000	3000 - 5000	460

1.1.2 Maximum tripping speed of the overspeed governor and maximum rated speed of the lift

The maximum tripping speed of the overspeed governor and the maximum rated speed of the lift must be calculated on the basis of the traction sheave's maximum tripping rotary speed as outlined above taking into account traction sheave diameter and car suspension.

$$v = \frac{D_{TS} \times \pi \times n}{60 \times i}$$

$v$  = Tripping (rated) speed (m/s)  
 $D_{TS}$  = Diameter of the traction sheave from rope's center to rope's center (m)  
 $\pi$  = 3,14  
 $n$  = Rotary speed (rpm)  
 $i$  = Ratio of the car suspension

**1.2 Use as braking element – part of the protection device against unintended car movement (acting in up and down direction) – permissible brake torques, tripping rotary speeds and characteristics**

1.2.1 Nominal brake torques and response times with relation to a brand-new brake element

Name / Size	Minimum nominal brake torque *[Nm]	Medium nominal brake torque * [Nm]	Maximum nominal brake torque * [Nm]	Maximum tripping rotary speed [rpm]	Maximum response times** [ms]		
					without / with Overexcitation		
					$t_0$	$t_{50}$	$t_{90}$
RTW 600	2 x 400 = 800			500	45 / --	95 / --	135 / ---
RTW 600		2 x 550 = 1100			25 / --	60 / --	100 / ---
RTW 600			2 x 600 = 1200		-- / 30	-- / 65	--- / 110
RTW 800	2 x 550 = 1100				100 / ---	180 / ---	280 / ---
RTW 800		2 x 850 = 1700			40 / --	100 / ---	150 / ---
RTW 800			2 x 1000 = 2000		-- / 60	--- / 115	--- / 160
RTW 1000	2 x 800 = 1600				85 / --	160 / ---	240 / ---
RTW 1000		2 x 1200 = 2400			40 / --	95 / --	150 / ---
RTW 1000			2 x 1350 = 2700		-- / 45	--- / 110	--- / 170
RTW 2000	2 x 1500 = 3000				460	150 / --	230 / ---
RTW 2000		2 x 2200 = 4400		90 / --		150 / --	250 / ---
RTW 2000			2 x 2500 = 5000	-- / 100		--- / 165	--- / 260

**Annex to the Type Examination Certificate  
No. UK-BD 1014/1 of 2022-05-27**



**Interim values can be interpolated**

**Explanations:**

- \* **Nominal brake torque:** Brake torque assured for installation operation by the safety component manufacturer.
- \*\* **Response times:**  $t_x$  time difference between the drop of the braking power until establishing X% of the nominal brake torque,  $t_{50}$  optionally calculated  $t_{50} = (t_{10} + t_{90})/2$  or value taken from the examination recording

**1.2.2 Assigned execution features**

Type of powering / deactivation	continuous current / continuous current end
Brake control	parallel
Nominal air gap	0.45 mm
Damping elements	YES
Overexcitation	at double non-release voltage

**2 Conditions**

- 2.1 Above mentioned safety component represents only a part at the protection device against overspeed for the car moving in upwards direction and unintended car movement. Only in combination with a detecting and triggering component in accordance with the standard (two separate components also possible), which must be subjected to an own type-examination, can the system created fulfil the requirements for a protection device.
- 2.2 The installer of a lift must create an examination instruction to fulfil the overall concept, add it to the lift documentation and provide any necessary tools or measuring devices, which allow a safe examination (e. g. with closed shaft doors).
- 2.3 The manufacturer of the drive unit must provide calculation evidence that the connection traction sheave – shaft – brake disc and the shaft itself is sufficiently safe, if the brake disc is not a direct component of the traction sheave (e. g. casted on). The shaft itself has to be statically supported in two points.  
The calculation evidence must be enclosed with the technical documentation of the lift.
- 2.4 The setting of the brake torque has to be secured against unauthorized adjustment (e. g. sealing lacquer).
- 2.5 The identification drawing no. E02810400000261 including stamp dated 2016-09-09 shall be included to the type examination for the identification and information of the general construction and operation and distinctness of the approved type.
- 2.6 The type examination certificate may only be used in combination with the corresponding annex and enclosure (List of authorized manufacturer of the serial production). The enclosure will be updated immediately after any change by the certification holder.

**3 Remarks**

- 3.1 In the scope of this type examination it was found out, that the brake device also functions as a brake for normal operation, is designed as a redundant system and therefore meets the requirements to be used also as a part of the protection device against overspeed for the car moving in upwards direction and as braking element as part of the protection device against unintended car movement.
- 3.2 Checking whether the requirements as per section 5.9.2.2 of EN 81-20:2020 (D) have been complied with is not part of this type examination.
- 3.3 Other requirements of the standard, such as reduction of brake moment respectively brake force due to wear or operational caused changes of traction are not part of this type examination.

**Annex to the Type Examination Certificate  
No. UK-BD 1014/1 of 2022-05-27**



- 3.4 This type examination certificate was issued according to the following standards:
- EN 81-1:1998 + A3:2009 (D), Annex F.7 and F.8
  - EN 81-20:2014 (D), part 5.6.6.11, 5.6.7.13
  - EN 81-50:2014 (D), part 5.7 and 5.8
  - EN 81-20:2020 (D), part 5.6.6.11, 5.6.7.13
  - EN 81-50:2020 (D), part 5.7 and 5.8
- 3.5 A revision of this type examination certificate is inevitable in case of changes or additions of the above mentioned standards or of changes of state of the art.

**Enclosure to the Type Examination Certificate  
No. UK-BD 1014/1 of 2022-05-27**



**Authorised Manufacturer of Serial Production – Production Sites (valid from: 2022-04-14):**

**Company** Chr. Mayr GmbH & Co. KG  
**Address** Eichenstr. 1  
87665 Mauerstetten - Germany

**Company** Mayr Polska Sp. z o. o.  
**Address** Rojów, ul. Hetmanska 1  
63-500 Ostrzesów - Poland

- END OF DOCUMENT -

Lüftversion für Bowdenzug  
(optional)

Lüftversion von Hand  
(optional)

Mikroschalter /  
micro switch/  
micro-interrupteur  
Initiator /  
proximity switch/  
Initiateur

Version  
verzahnte Welle

Version  
Nabe  
(optional)

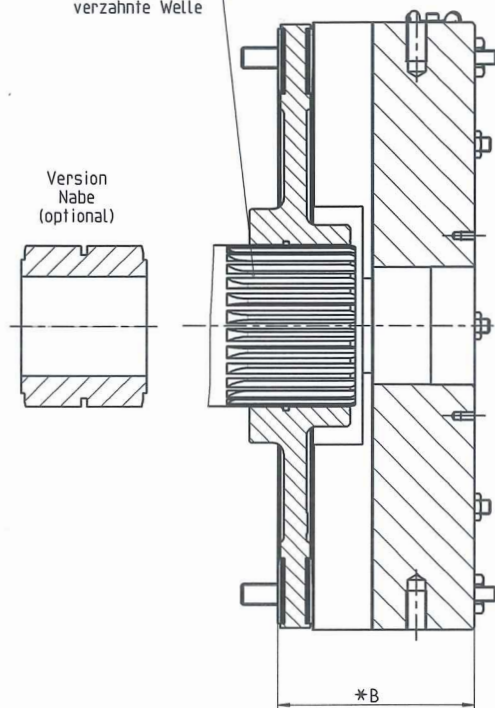
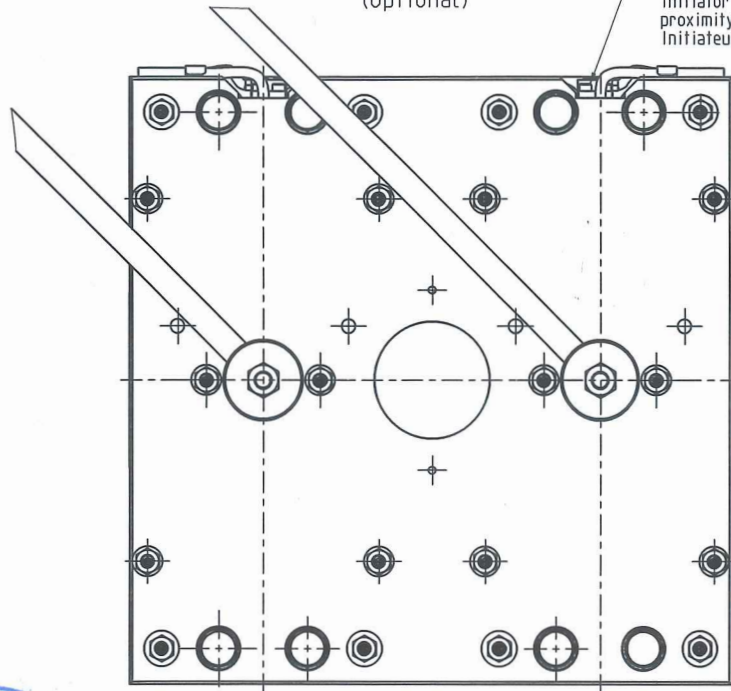
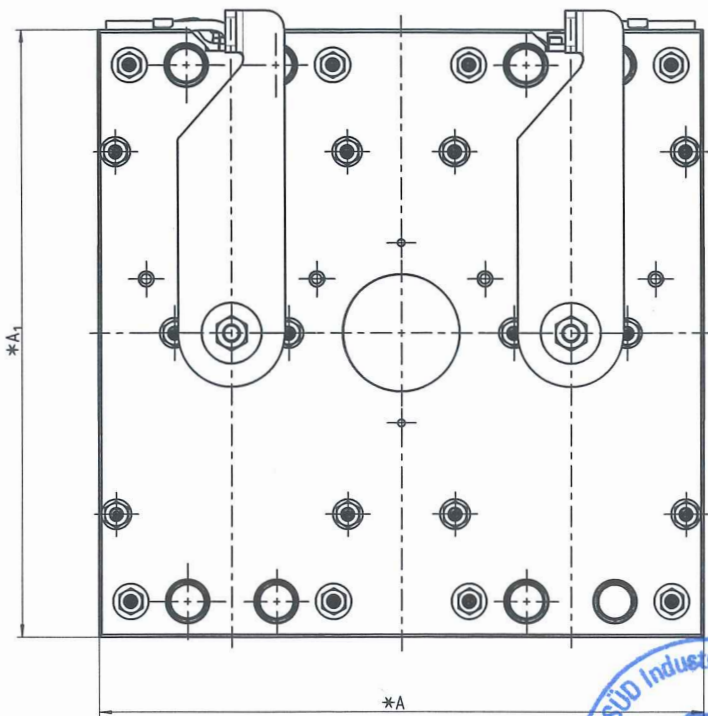

9. SEP. 2016

**GEPRÜFT / APPROVED**  
TÜV SÜD Industrie Service GmbH  
Prüflaboratorium für Produkte der Fördertechnik  
Westendstraße 199  
80686 München  
Sachverständiger / Expert

*M. Nagmann*

\* Maße variabel/  
dimensions variable/  
dimensions variables

Größe/ size/ taille	A	A <sub>1</sub>	B
600	315	303	102.6
800	340	340	112
1000	340	380	126
2000	410	425	135

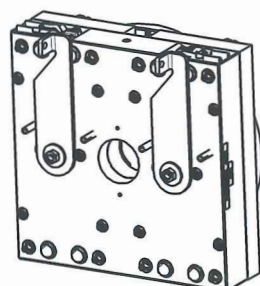
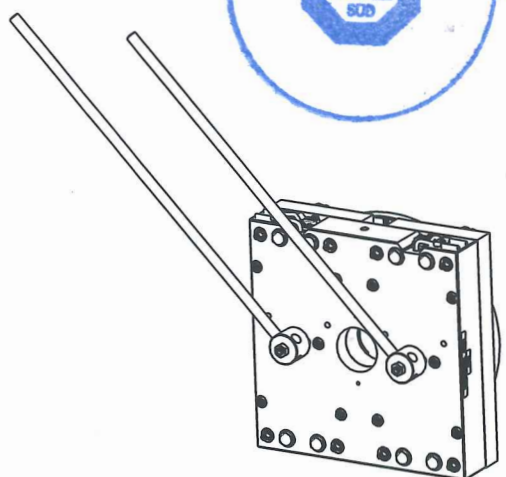

Datum / date: 16.11.2016		Name / name: FACHM		Werkstoff-ler./material-no.:		Schulnumm. / project no.:		DIN ISO 9001			
Gezeichnet / drawn:		Geprüft / checked:		Berechnung / approved:		Oberfläche / surface DIN EN ISO 1302 Ra = μm(√)		Werkstückkanten / edges DIN EN ISO 13715		Werkstoff / material:  alternativ / alternative: Allgen.-Toleranzen / general tolerance DIN ISO 2768-MS	
Besetzung / part name:		Artikelnummer / part number:		Dokumentnummer / document number:		Zeichnungsnummer / drawing number:		Chr. MAYR GMBH • CO.KG Eichenstraße 1 87665 Flußertellen www.mayr.com		4851654 E02810400000261	
Maßstab / scale:		Type / type:		Größe / size:		Gewicht / weight:		RTW Baugröße 600 - 2000 Type 8012		8012	

letzte Aktualisierung: 26.07.2016